

SC Series

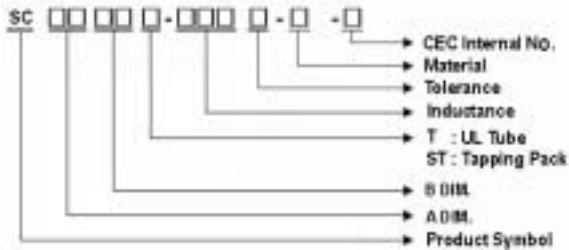

Product Identification



Electrical Parameters

Part Number	Inductance @ 1KHz, 1V	D.C. Resistance (Ω) Max	D.C. Current (mA) Min
SC0717□-3R9-N	3.9	0.019	3600
SC0717□-4R7-N	4.7	0.022	2800
SC0717□-5R6-N	5.6	0.024	2600
SC0717□-6R8-N	6.8	0.026	2200
SC0717□-8R2-N	8.2	0.028	2100
SC0717□-100-N	10	0.033	1700
SC0717□-120-N	12	0.037	1700
SC0717□-150-N	15	0.040	1400
SC0717□-180-N	18	0.044	1300
SC0717□-220-N	22	0.050	1200
SC0717□-270-N	27	0.058	1100
SC0717□-330-N	33	0.075	950
SC0717□-390-N	39	0.094	900
SC0717□-470-N	47	0.109	830
SC0717□-560-N	56	0.140	750
SC0717□-680-N	68	0.131	700
SC0717□-820-N	82	0.152	600
SC0717□-101-N	100	0.208	550
SC0717□-121-N	120	0.283	500
SC0717□-151-N	150	0.34	450
SC0717□-181-N	180	0.362	450
SC0717□-221-N	220	0.43	350
SC0717□-271-N	270	0.557	300
SC0717□-331-N	330	0.665	300
SC0717□-391-N	390	0.772	250
SC0717□-471-N	470	1.15	250
SC0717□-561-N	560	1.27	250
SC0717□-681-N	680	1.61	200
SC0717□-821-N	820	1.96	200
SC0717□-102-N	1000	2.30	180
SC0717□-122-N	1200	2.65	170
SC0717□-152-N	1500	3.40	140
SC0717□-182-N	1800	4.03	130
SC0717□-222-N	2200	4.38	120
SC0717□-272-N	2700	5.40	100
SC0717□-332-N	3300	6.56	95
SC0717□-392-N	3900	8.63	90
SC0717□-472-N	4700	9.66	80
SC0717□-562-N	5600	13.9	70
SC0717□-682-N	6800	16.3	60
SC0717□-822-N	8200	20.8	60
SC0717□-103-N	10000	26.4	55
SC0717□-123-N	12000	29.9	45
SC0717□-153-N	15000	42.5	45
SC0717□-183-N	18000	48.3	40

Shapes and Dimensions

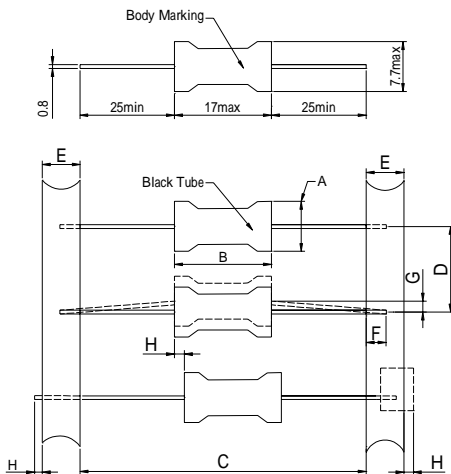

Dimensions in mm

A	8.5 ⁺⁰	F	3.2 ⁻⁰
B	17 ⁺⁰	G	1.2 ⁺⁰
C	73±1.5	H	0.8 ⁺⁰
D	10±0.5		
E	6±1		

Test Instrument

- L: HP 4192A LF IMPEDANCE ANALYZER
- D.C. CURRENT: CHEN HWA CH1061+301A
- D.C. RESISTANCE: CHEN HWA502BC

Note:

- lead-free
- CHILISIN has UL tube on SC Series to avoid the damage when wave soldering.



Features

- Low cost
- Wide range of inductance
- High reliability

Product Identification

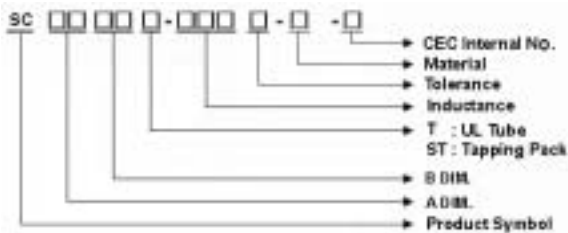

Shapes and Dimensions

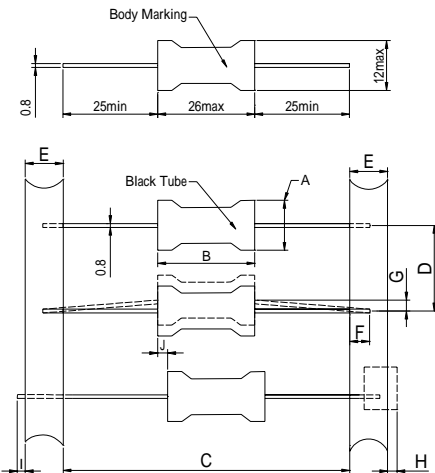

Dimension in mm

A	12.5 ⁺⁰	F	3.2 ⁻⁰
B	26 ⁺⁰	G	1.2 ⁺⁰
C	73±1.5	H	0.8 ⁺⁰
D	15±0.5	I	0.8 ⁺⁰
E	6±1	J	0.8 ⁺⁰

Test Instrument

- L: HP 4192A LF IMPEDANCE ANALYZER
- D.C. CURRENT: CHEN HWA CH1061+301A
- D.C. RESISTANCE: CHEN HWA502BC

Note:

- lead-free identification.
- CHILISIN uses UL tube on SC Series to avoid the damage when wave soldering.

Electrical Parameters

Part Number	Inductance @ 1KHz, 1V	D.C. Resistance (Ω) Max	D.C Current (mA) Min
SC1126□-100-N	10±15%	0.023	4200
SC1126□-120-N	12±15%	0.025	3600
SC1126□-150-N	15±15%	0.030	3400
SC1126□-180-N	18±15%	0.032	3100
SC1126□-220-N	22±15%	0.035	2700
SC1126□-270-N	27±15%	0.038	2400
SC1126□-330-N	33±15%	0.043	2200
SC1126□-390-N	39±15%	0.047	1800
SC1126□-470-N	47±15%	0.054	1800
SC1126□-560-N	56±15%	0.060	1500
SC1126□-680-N	68±15%	0.068	1500
SC1126□-820-N	82±15%	0.073	1300
SC1126□-101-N	100±15%	0.098	1200
SC1126□-121-N	120±15%	0.140	1100
SC1126□-151-N	150±15%	0.180	1000
SC1126□-181-N	180±15%	0.200	940
SC1126□-221-N	220±15%	0.280	800
SC1126□-271-N	270±15%	0.31	800
SC1126□-331-N	330±15%	0.35	600
SC1126□-391-N	390±15%	0.38	600
SC1126□-471-N	470±15%	0.44	500
SC1126□-561-N	560±15%	0.48	500
SC1126□-681-N	680±15%	0.63	450
SC1126□-821-N	820±15%	0.87	450
SC1126□-102-N	1000±15%	0.96	400
SC1126□-122-N	1200±15%	1.3	390
SC1126□-152-N	1500±15%	1.4	300
SC1126□-182-N	1800±15%	1.7	300
SC1126□-222-N	2200±15%	2.3	260
SC1126□-272-N	2700±15%	2.6	250
SC1126□-332-N	3300±15%	3.5	200
SC1126□-392-N	3900±15%	3.8	200
SC1126□-472-N	4700±15%	4.3	180
SC1126□-562-N	5600±15%	5.6	170
SC1126□-682-N	6800±15%	6.3	140
SC1126□-822-N	8200±15%	8.6	140
SC1126□-103-N	10000±15%	9.7	120
SC1126□-123-N	12000±15%	11	110
SC1126□-153-N	15000±15%	15	100
SC1126□-183-N	18000±15%	20	95
SC1126□-223-N	22000±15%	24	85
SC1126□-273-N	27000±15%	26	80
SC1126□-333-N	33000±15%	35	70
SC1126□-393-N	39000±15%	38	65
SC1126□-473-N	47000±15%	50	60
SC1126□-563-N	56000±15%	55	55
SC1126□-683-N	68000±15%	76	50
SC1126□-823-N	82000±15%	86	45
SC1126□-104-N	100000±15%	99	40
SC1126□-124-N	120000±15%	110	40
SC1126□-154-N	150000±15%	200	35
SC1126□-184-N	180000±15%	220	30
SC1126□-224-N	220000±15%	300	25
SC1126□-274-N	270000±15%	320	25
SC1126□-334-N	330000±15%	420	25
SC1126□-394-N	390000±15%	480	20
SC1126□-474-N	470000±15%	670	20
SC1126□-564-N	560000±15%	730	20
SC1126□-684-N	680000±15%	870	15
SC1126□-824-N	820000±15%	950	15
SC1126□-105-N	1000000±15%	1100	15



Features

- Low cost
- Wide range of inductance
- High reliability

Product Identification

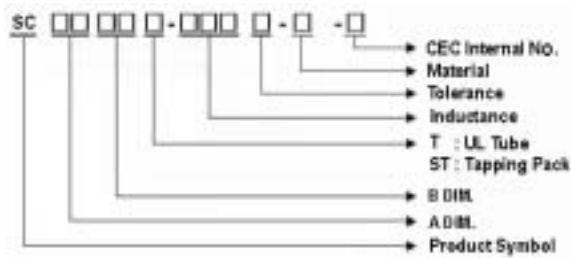

Shapes and Dimensions

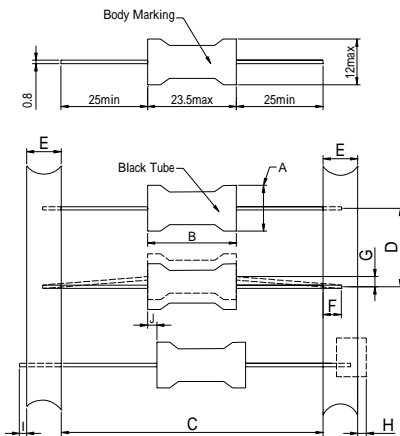

Dimension in mm

A	12 ⁺⁰	F	3.2 ⁻⁰
B	23.5 ⁺⁰	G	1.2 ⁺⁰
C	73±1.5	H	0.8 ⁺⁰
D	15±0.5	I	0.8 ⁺⁰
E	6±1	J	0.8 ⁺⁰

Test Instrument

- L: HP 4192A LF IMPEDANCE ANALYZER
- D.C. CURRENT: CHEN HWA CH1061+301A
- D.C. RESISTANCE: CHEN HWA502BC

Note:

- lead-free
- CHILISIN has UL tube on SC Series. to avoid the damage when wave soldering.

Electrical Parameters

Part Number	Inductance @ 1KHz, 1V	D.C. Resistance (Ω) Max	D.C Current (mA) Min
SC1223□-3R9-N	3.9±15%	0.007	4500
SC1223□-4R7-N	4.7±15%	0.008	4000
SC1223□-5R6-N	5.6±15%	0.009	3500
SC1223□-6R8-N	6.8±15%	0.011	3300
SC1223□-8R2-N	8.2±15%	0.013	2900
SC1223□-100-N	10±15%	0.017	2700
SC1223□-120-N	12±15%	0.019	2400
SC1223□-150-N	15±15%	0.022	2100
SC1223□-180-N	18±15%	0.023	1900
SC1223□-220-N	22±15%	0.026	1700
SC1223□-270-N	27±15%	0.027	1500
SC1223□-330-N	33±15%	0.032	1400
SC1223□-390-N	39±15%	0.033	1300
SC1223□-470-N	47±15%	0.035	1200
SC1223□-560-N	56±15%	0.037	1100
SC1223□-680-N	68±15%	0.047	1400
SC1223□-820-N	82±15%	0.060	1300
SC1223□-101-N	100±15%	0.080	1200
SC1223□-121-N	120±15%	0.090	1100
SC1223□-151-N	150±15%	0.120	940
SC1223□-181-N	180±15%	0.140	900
SC1223□-221-N	220±15%	0.160	800
SC1223□-271-N	270±15%	0.180	770
SC1223□-331-N	330±15%	0.212	620
SC1223□-391-N	390±15%	0.260	600
SC1223□-471-N	470±15%	0.281	510
SC1223□-561-N	560±15%	0.380	480
SC1223□-681-N	680±15%	0.500	470
SC1223□-821-N	820±15%	0.548	430
SC1223□-102-N	1000±15%	0.655	380
SC1223□-122-N	1200±15%	0.884	350
SC1223□-152-N	1500±15%	1.040	310
SC1223□-182-N	1800±15%	1.180	290
SC1223□-222-N	2200±15%	1.568	250
SC1223□-272-N	2700±15%	2.06	220
SC1223□-332-N	3300±15%	2.53	210
SC1223□-392-N	3900±15%	2.75	200
SC1223□-472-N	4700±15%	3.19	170
SC1223□-562-N	5600±15%	3.92	150
SC1223□-682-N	6800±15%	6.69	140
SC1223□-822-N	8200±15%	6.32	130
SC1223□-103-N	10000±15%	7.30	110
SC1223□-123-N	12000±15%	9.21	100
SC1223□-153-N	15000±15%	10.5	95
SC1223□-183-N	18000±15%	14.8	90
SC1223□-223-N	22000±15%	21.8	80
SC1223□-273-N	27000±15%	22.7	70
SC1223□-333-N	33000±15%	25.7	60
SC1223□-393-N	39000±15%	33.0	60
SC1223□-473-N	47000±15%	36.1	60
SC1223□-563-N	56000±15%	40.9	55
SC1223□-683-N	68000±15%	57.3	45
SC1223□-823-N	82000±15%	79.3	40
SC1223□-104-N	100000±15%	89.7	40